

FLOOR PLAN DETAIL

Schedule of Door & Windows

Name	Lintel	Width	Sill lvl	Description
D1	2.10	0.90	--	
D2	2.10	0.75	--	PVC DOOR
W1	2.10	1.50	0.90	
W2	2.10	0.90	0.90	
V	2.10	0.60	1.65	

NOTES:-

Clear height of DU = 2.85 m
 Chajja projection over windows is 450 mm .
 * All the Dimensions in m

Dr. Pardeep Kumar
 Associate Professor (Structural Engg.)
 Department of Civil Engineering
 National Institute of Technology
 Hamirpur (H.P.)-177005

NOTES:-

- All dimensions are in m, unless wherever specified diameter of the bars shown in mm
- Dimensions are not to be scaled out, only written dimensions may be taken as correct.
- Nominal mix concrete 1:1.5:3 according IS 456 Clause 9.3
- The reinforcement shall be of high strength deformed steel bars conforming to IS:1786-2008
- Lap length and development length (L_d) for 8mm Φ is 400 mm
- Second class brick must be used
- Mortar 1:5 as per Table 3 IS 4326-2013
- All walls are one Brick Thick Masonry walls or Autoclaved Aerated Block of Class 7.5
- Any discrepancy in the structural drawings should be correlated with architectural drawing.
- Partition Wall of WC and Bath shall be constructed till full height after slab casting
- Refer DWG-2 to DWG-4 for earthquake resistance and structural detail.

DRG. No. - NIT/CED/2017/PMAY -OP1-MB-FR-ZIV/DWG-1

NATIONAL INSTITUTE OF TECHNOLOGY HAMIRPUR

BUILDING NAME:
 PMAY HFA
 OPTION 1
 MASONRY BUILDING
 FLAT ROOF
 ZONE IV

DRAWING TITLE:
 FLOOR PLAN

DESIGNED BY:
 Dr. Pardeep Kumar
 Dr. Hemant Kumar Vinayak

Dr. Hemant Kumar Vinayak
 Assistant Professor
 Department of Civil Engineering
 National Institute of Technology,
 Hamirpur -177005 (H.P.)

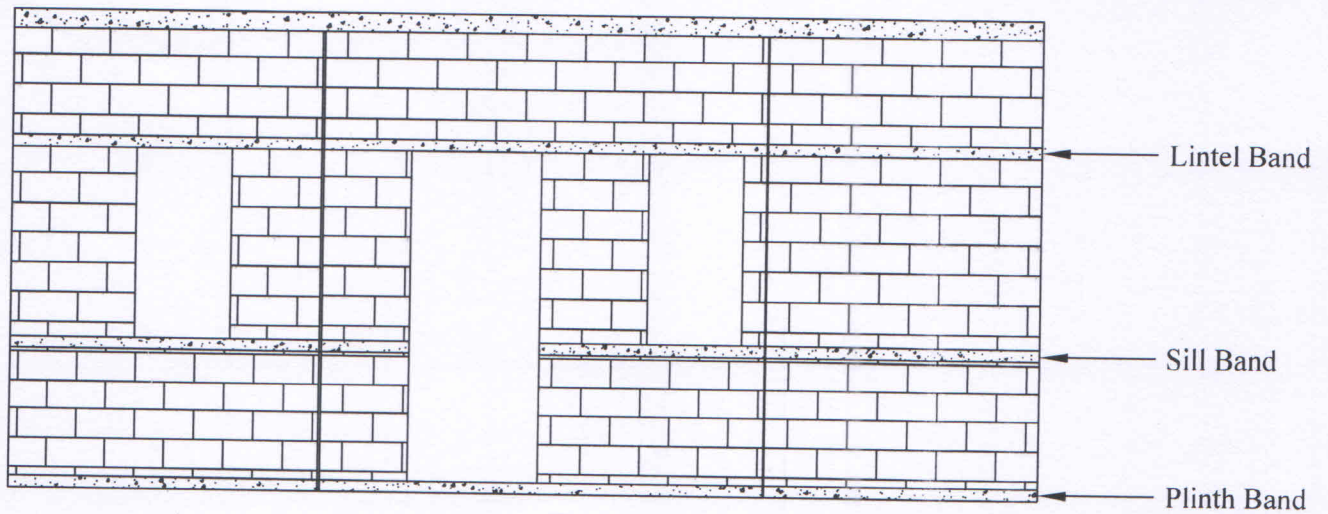

ELEVATION

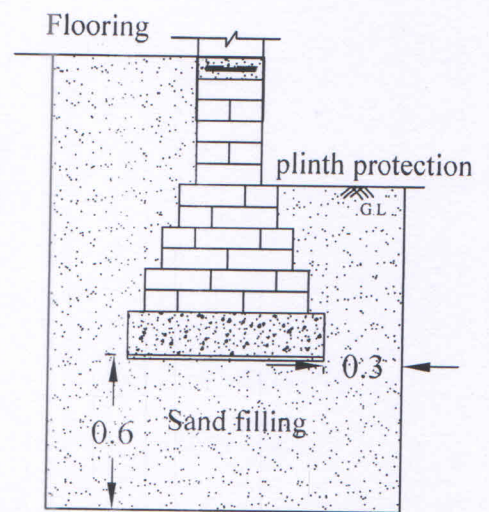
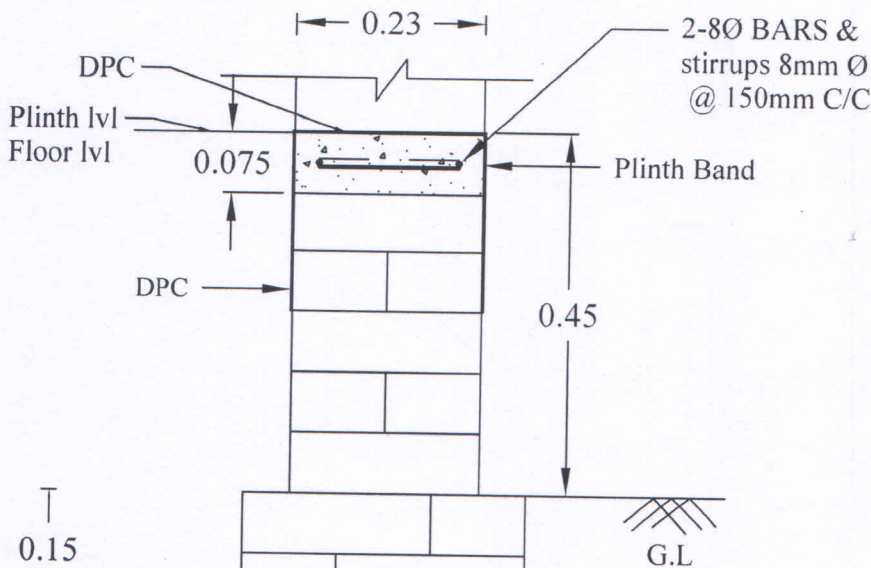

- In case of foundation to be constructed in expansive soil
- Clear cover for the reinforcement should be 30mm.

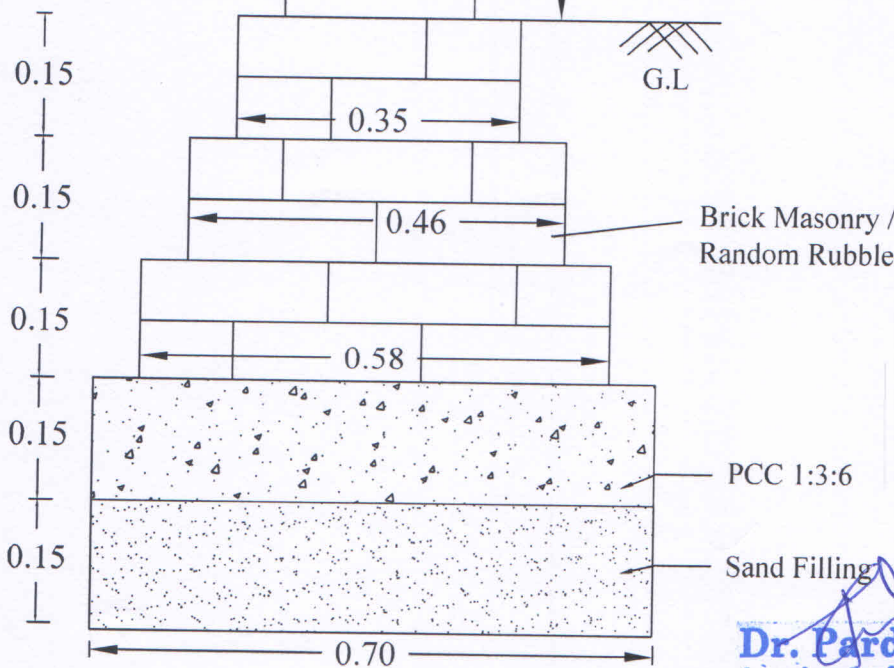

FOOTING DETAILS

DRG. No. - NIT/CED/2017/PMA
-OP1-MB-FR-ZIV/DWG-2

NATIONAL INSTITUTE OF
TECHNOLOGY HAMIRPUR

BUILDING NAME:
PMAY HFA
OPTION 1
MASONRY BUILDING
FLAT ROOF
ZONE IV

DRAWING TITLE:
FOOTING DETAIL &
ELEVATION

DESIGNED BY:

Dr. Pardeep Kumar

Dr. Hemant Kumar Vinayak

Dr. Pardeep Kumar
Associate Professor (Structural Engg.)
Department of Civil Engineering
National Institute of Technology
Hamirpur (H.P.)-177005

• All dimensions are in meter

Dr. Hemant Kumar Vinayak
Assistant Professor
Department of Civil Engineering
National Institute of Technology,
Hamirpur -177005 (H.P.)

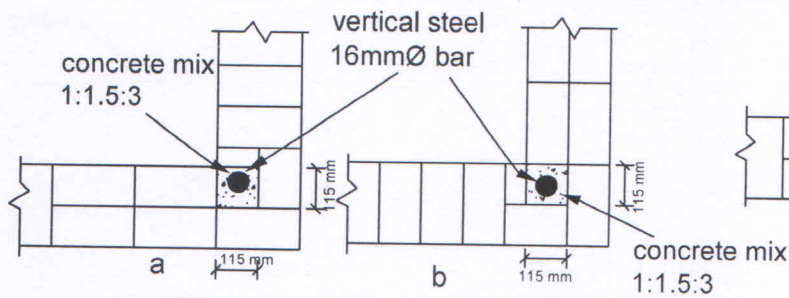

CORNER VERTICAL STEEL
a & b :- alternate courses in one brick wall

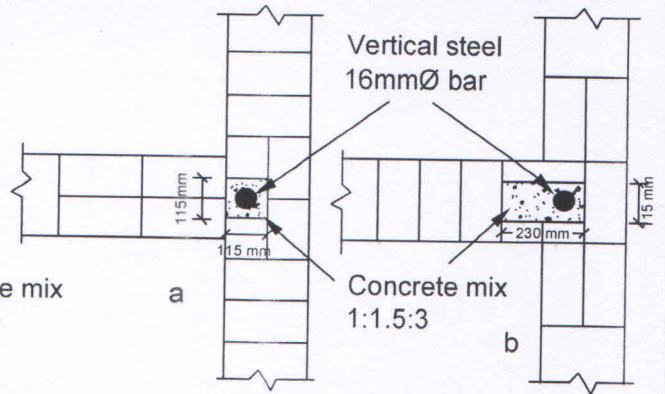

INTERMEDIATE VERTICAL STEEL
a & b :- alternate courses in one brick wall

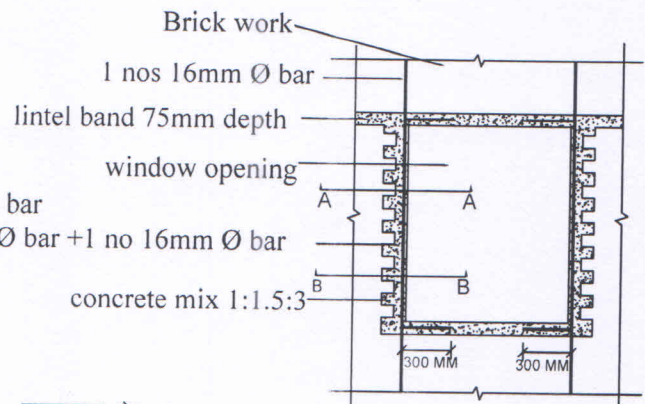
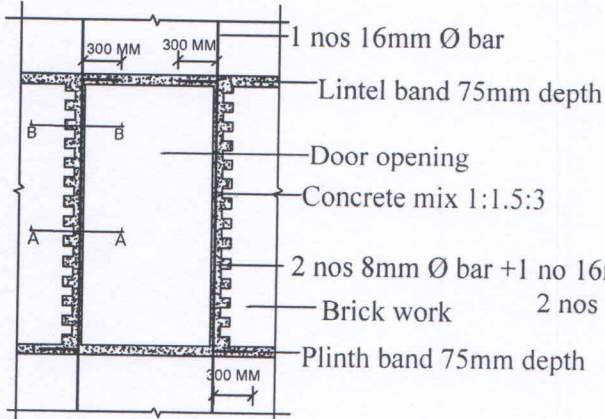

DETAIL OF R/F AROUND DOOR

DETAIL OF R/F AROUND WINDOW

- Lap length and development length (L_d) for 8mm Φ is 400 mm
- Clear cover for band should be 30mm.

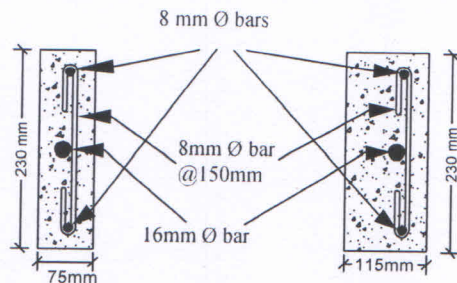

SECTION A-A

SECTION B-B

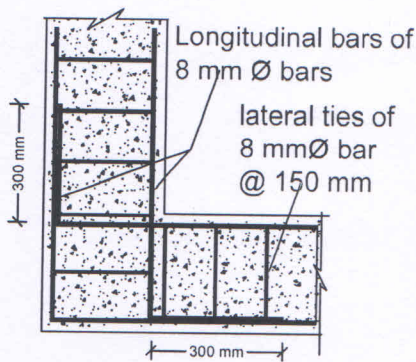

DETAIL OF PLINTH/LINTEL BAND

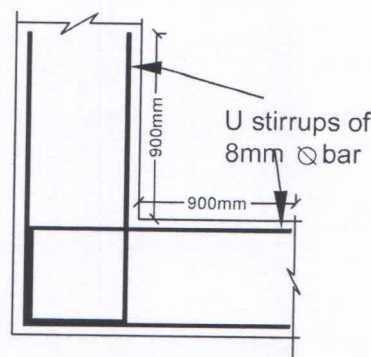

PLAN OF SILL LEVEL R/F

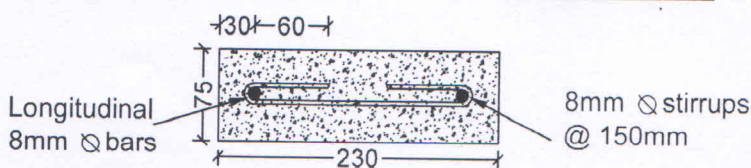

SECTION OF PLINTH/LINTEL BAND

DRG. No. - NIT/CED/2017/PMAY
-OP1-MB-FR-ZIV/DWG-3

NATIONAL INSTITUTE OF
TECHNOLOGY HAMIRPUR

BUILDING NAME:
PMAY HFA
OPTION 1
MASONRY BUILDING
FLAT ROOF
ZONE IV

DRAWING TITLE:
DETAILS OF R/F AROUND
WINDOW & DOOR,
VERTICAL R/F,
CROSS SECTION OF BAND

DESIGNED BY:
Dr. Pardeep Kumar
Dr. Hemant Kumar Vinayak

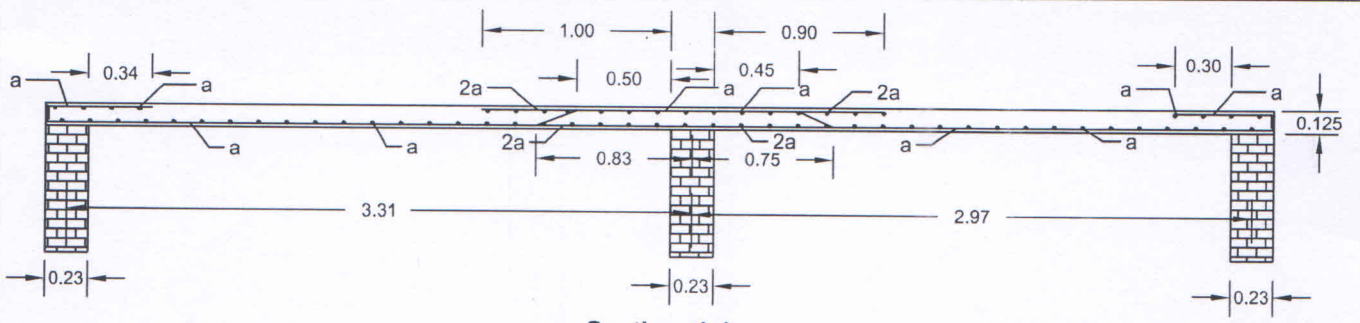

Section 1-1

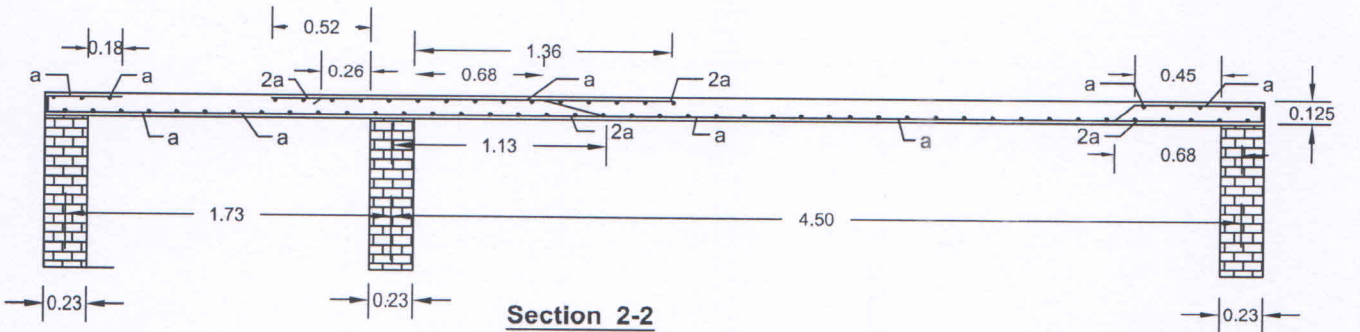

Section 2-2

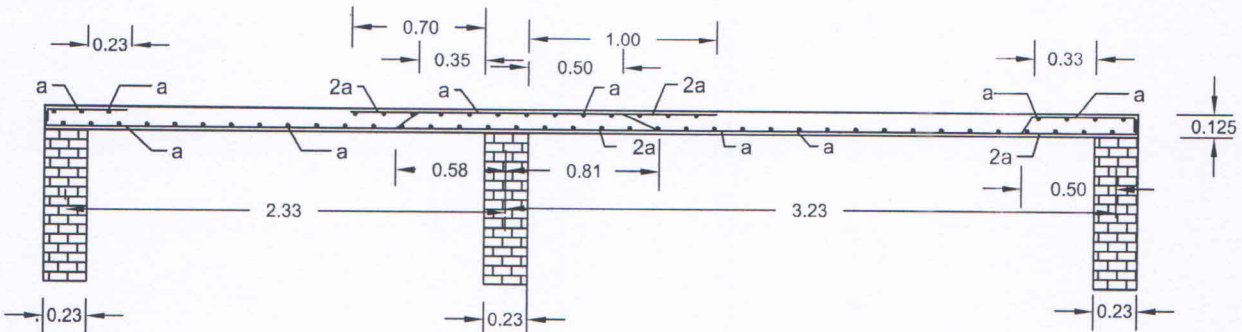

Section 3-3

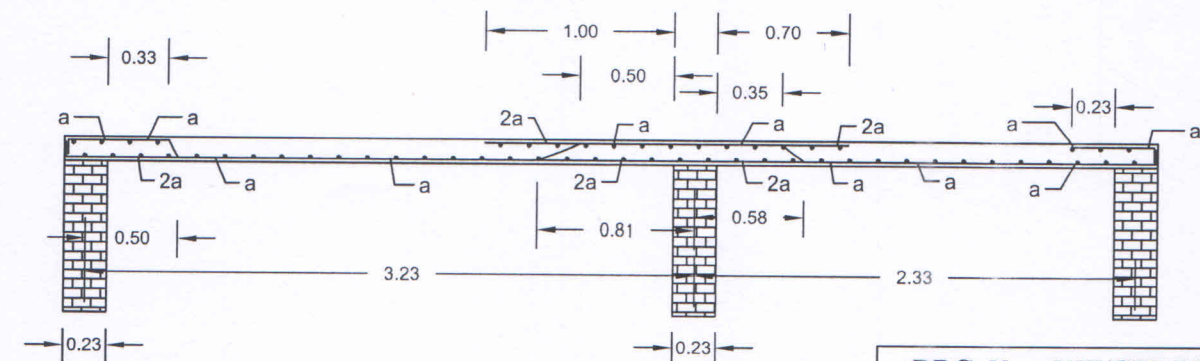

Section 4-4

- Clear cover for slab should be 20mm.
- All dimensions are in meter

SCHEDULE OF BARS
a. 8 mm ϕ @ 150 mm c/c

Hemant Kumar Vinayak
Dr. Hemant Kumar Vinayak
Assistant Professor
Department of Civil Engineering
National Institute of Technology,
Hamirpur -177005 (H.P.)

Pardeep Kumar
Dr. Pardeep Kumar
Associate Professor (Structural Engg.)
Department of Civil Engineering
National Institute of Technology
Hamirpur (H.P.)-177005

DRG. No. - NIT/CED/2017/PMAY - OP1-MB-FR-ZIV/DWG-4

NATIONAL INSTITUTE OF TECHNOLOGY HAMIRPUR

**BUILDING NAME:
PMAY HFA OPTION 1
MASONRY BUILDING
FLAT ROOF ZONE IV**

**DRAWING TITLE:
SLAB DETAILS**

**DESIGNED BY:
Dr. Pardeep Kumar
Dr. Hemant Kumar Vinayak**